

STRAIN MEASUREMENT FOR STRUCTURAL HEALTH MONITORING USING FIBER BRAGG GRATING SENSORS

K. VINNARASI^{a1} AND S. SUNDARAVADIVELU^b

^aPG Scholar, Department of ECE, SSN College of Engineering, Chennai, India

^bProfessor, Department of ECE, SSN College of Engineering, Chennai, India

ABSTRACT

In this paper the wavelength shift due to strain is measured by using Fiber Bragg Grating sensors. Structural health monitoring is the emerging field where it involves monitoring of several physical parameters. Strain measurement is one of the most external parameter to be measured in various sensing applications. The conventional strain sensors used to measure strain has many disadvantages in terms of low stability, not immune to Electromagnetic Interference (EMI) and other external factors. The Fiber Bragg Grating Sensors has replaced the sensor like strain gauge in various remote applications. The work is centered on fiber optic Bragg grating (FBG) sensors, to detect strains with the wavelength shift that is observed due to the physical perturbation. This kind of strain analysis can be used to monitor strain in complex structures and in remote applications

KEYWORDS: Fiber Bragg Grating Sensor Strain Measurement, Structural Health Monitoring, Comsol Software.

Fiber-optic communication industries have significantly reduced optical component prices and improved quality. FBG sensors introduce a great number of advantages. They allow to obtain absolute measures obtained analyzing the Bragg wavelength shift induced by the measured parameters. The production costs are very low, making this family of sensors competitive also in the comparisons of the electrical strain gauges.

Fiber Bragg grating strain sensors does not break at any case of cracks. Using Comsol software a 2-D and 3-D model for crack detection was designed. Strain is developed by the pressure wave produced due to crack. So the concrete material is to be used for simulation process. This paper uses a FBG sensor that works based on shift in Bragg wavelength due to strain. Instead of sensing strain is to be sensed.

Design

To create the 2D model using COMSOL. To measure the strain using probe points for detecting the crack in concrete. In real time applications the probe points are replaced by the fiber Bragg grating (FBG) sensors. The whole block was assigned the concrete material, which are in the Comsol material library.

Experimental setup To Determine Bragg Wavelength Shift

The connection of experimental procedure for strain measurement using SLED broad band light source, IMON, circulator and laptop with software. The broadband light that is sent to the FBG reflects a particular wavelength called the Bragg's wavelength. This reflected wavelength reaches the IMON via the third port of the circulator. Then the reflected

wavelength is noted in the IMON evaluation software. Now when the voltage is given to the PZT is increased in step which in turn produces the corresponding strain due to the stretching of PZT test bed. The strain produced is sensed by the FBG sensor. Due to the physical perturbation produced due to strain in the FBG, the wavelength that was reflected shifts accordingly. The shifted wavelength can be measured and based on which the strain produced can be measured.

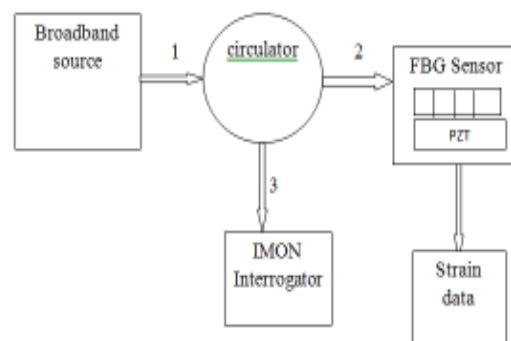

Figure 1: Experimental setup for determination of Bragg wavelength shift.

CRACK DETECTION

Simulation-2D model

Specifications for simulation using Comsol software:

- The Input (pressure) waveform shown in Fig. 5 was taken.
- The simulation done at time dependent study.

- Sensors location shown in Fig. 3 and 4 shown the strain creation.

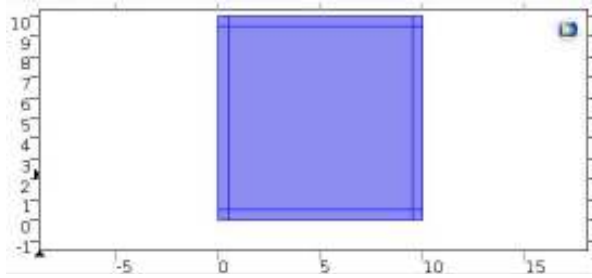

Figure 2: 2D model - concrete material assigned.

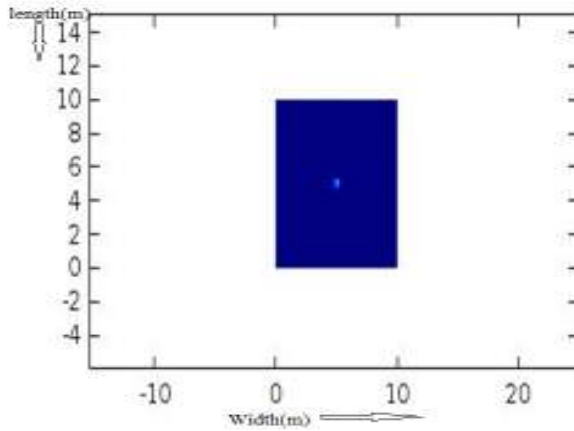

Figure 3: Strain creation of single point source

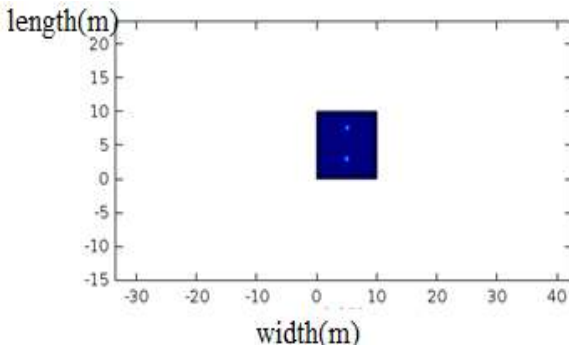

Figure 4: Source at different point.

Input Waveform

The crack detection occurs due to the creation of strain. The pressure waveforms nature is a sudden rise and then an exponential decay. In this simulation part we have used the input pulse given below.

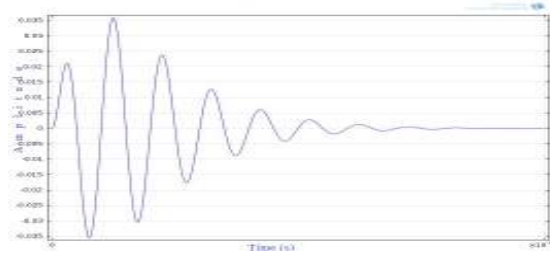

Figure 5: 2D Input (pressure) waveform

Mathematical representation of

$$\text{Input wave form} = A t * e^{-Bt} * \sin(2\pi * f)t$$

Strain plot for single point load

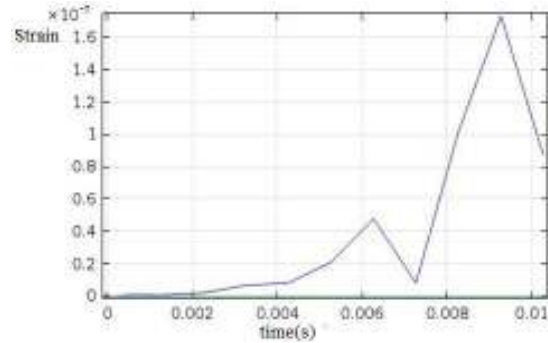

Figure 6: Strain plot for single point load using edge point probe.

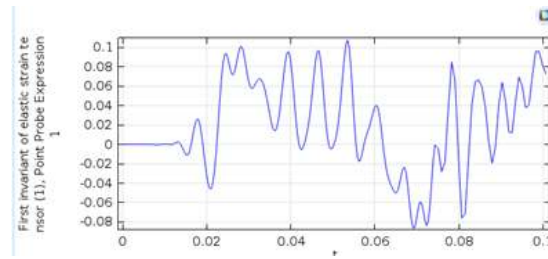
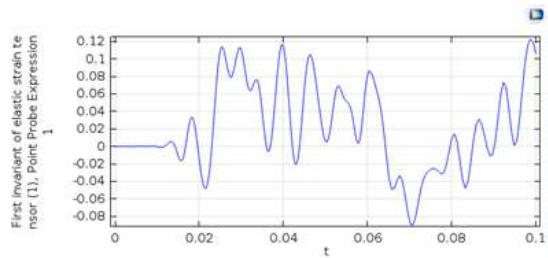
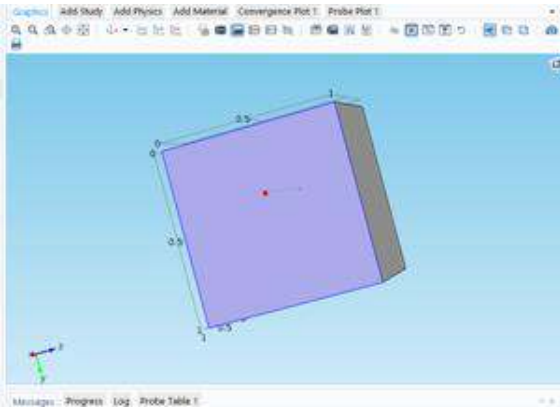

Figure 7: Strain plot for different point load using edge point probe.

Simulation-3D model



The figure. 8 shows the simple model for 3D using Comsol. Concrete material is to be assigned for the full block. It shows all the three dimension view with different dimensions for length, width, and height.

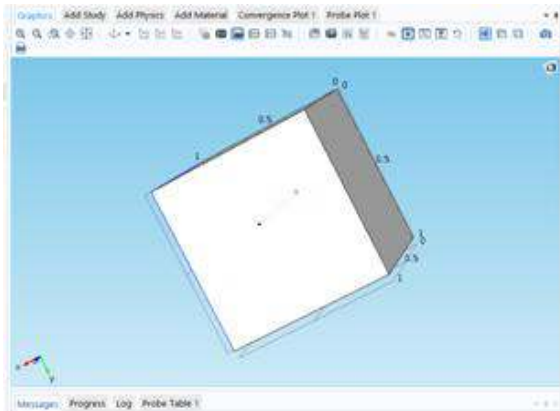

Figure 8: Different Point load

The fig. 9 and 4B shows the different point loads at the different directions X, Y,Z and the probes are fixed the edges using edge point probes.

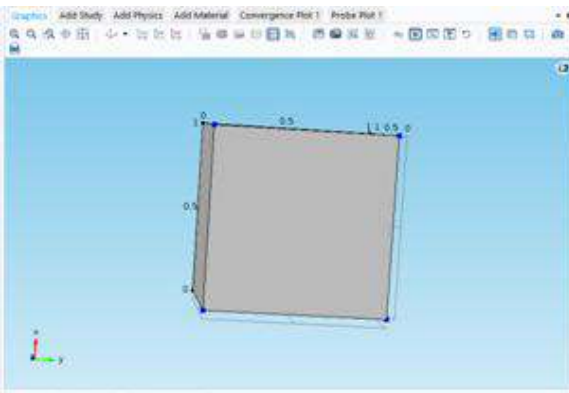

Figure 9: Placed Edge point probe

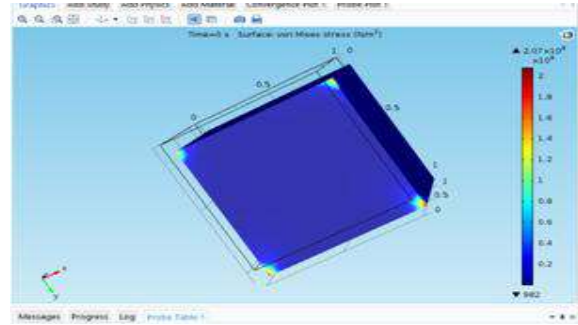

Figure 10: Strain creation-3Dmodel

This fig.10 shows the time dependent study for strain created, using 3D model..

Strain plot different point load for 3D model

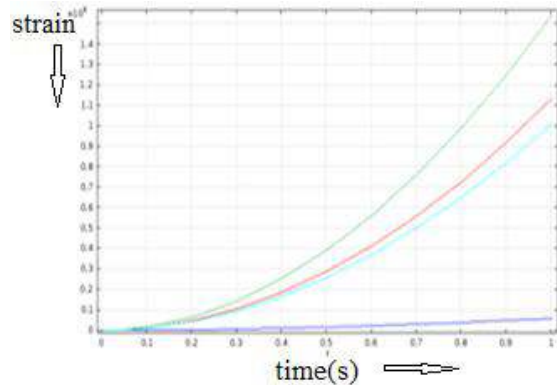

Figure 11: Strain plot for 3Dmodel.

The output waveform is produced. The value of the strain decreased at the particular point using the probe points. So only the real time applications the probe points are replaced by the Fiber Bragg Grating (FBG) sensors.

Experimental Setup

As per the fig. 12 shows the connection of experimental procedure for strain measurement using SLED broad band light source, IMON, circulator and laptop with software.



Figure 12: Experimental setup at IIT, Madras

For this experimental setup, the wavelength will shift in accordance to the strain done at IIT, Madras. The voltage value is varied in the steps of 3volts up to 30 volts. This variation in the voltage creates a strain which is in linear with the voltage applied to the PZT stretcher. Now when the voltage is given to the PZT is increased in step which in turn produces the corresponding strain due to the stretching of PZT test bed. The strain produced is sensed by the FBG sensor.



Figure 13: Bragg wavelength at zero strain in IMON evaluation software.

The fig. 13 shows the waveform obtained for the FBG reflected spectrum obtained from the FBG sensor which is noticed in the IMON evaluation software.

Bragg Wavelength and Power

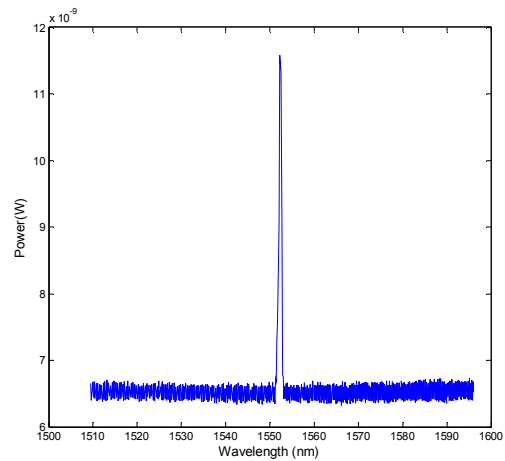

Figure 14: FBG reflected spectrum without strain

This fig. 14 shows the reflected spectrum without strain. The values are taken from IMON (Interrogator Monitor).It is interfaced using the Ethernet cables with the laptop with software. The concern pixel, wavelength values are saved in excel data sheet. Then each values are converted using MATLAB.

The fig: 5.13 shows the FBG reflected spectrum for the strain value of 0.348. The wavelength of the strain shifted from 1550nm in to 1552.3nm. the difference between the values of the 0 to 0.348 $\mu\epsilon$ is 2.3 $\mu\epsilon$.

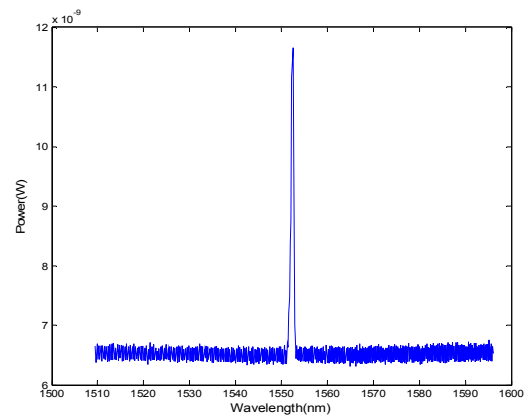

Figure 15: FBG reflected spectrum for 0.348 $\mu\epsilon$

The fig. 15 shows the FBG reflected spectrum for the strain value of 1.392 $\mu\epsilon$. The wavelength of the strain shifted from 1552.3 in to 1552.35nm. The difference between the values of the 0.348 $\mu\epsilon$ to 1.392 $\mu\epsilon$ is 0.05 $\mu\epsilon$.

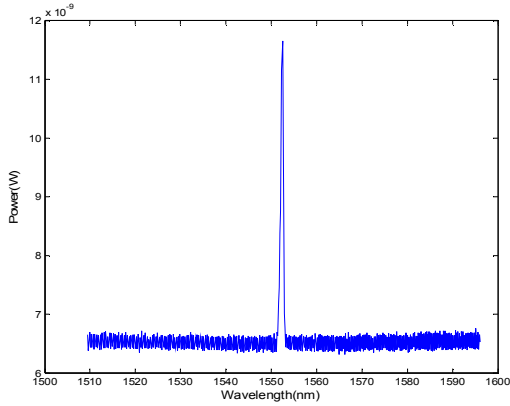

Figure 16: FBG reflected spectrum for 1.392 $\mu\epsilon$

The fig. 16 shows the FBG reflected spectrum for the strain value of 2.436. The wavelength of the strain shifted from 1552.35nm to 1552.50nm. The shift difference between the values of 1.392 $\mu\epsilon$ to 2.436 $\mu\epsilon$ is 0.15 $\mu\epsilon$.

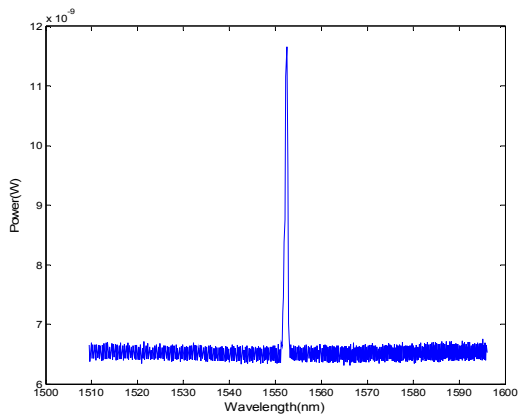

Figure 17: FBG Reflected spectrum for maximum strain

The fig. 17 shows the FBG reflected spectrum for the strain value of 2.436. The wavelength of the strain shifted from 1552.35nm to 1552.50nm. The shift difference between the values of 1.392 $\mu\epsilon$ to 2.436 $\mu\epsilon$ is 0.15 $\mu\epsilon$.

Table I. Tabulation of Strain Vs Wavelength

S. No.	Strain Value ($\mu\epsilon$)	Wave Length (nm)
1	0.348	1552.0
2	1.392	1552.30
3	2.436	1552.46
4	3.48	1552.50
5	1.5	1552.60

The tabulation shows the plot of strain versus wavelength. The values are obtained from IMON. The power versus wavelength values are taken and then the values are converted in to strain. From this conversion the minimum value of zero and maximum value of wavelength shift has to be calculated

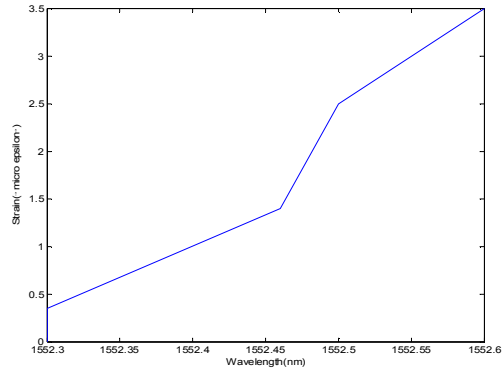

Figure 18: Bragg wavelength at maximum strain

To plot the graph using the values of strain and wavelength (nm). The wavelength shift for the strain values varies very minute. So the Fiber Bragg Grating sensors are stable at maximum strain compare to the probe points and other conventional sensors.

CONCLUSION

Bragg wavelength shift for zero strain and maximum strain was observed. From this result it is clear that we can fix the threshold strain level for safety of avoid the crack in buildings. I have measured the wavelength shift for different strain values increased in steps using FBG sensor. The shift in the wavelength from 1552.00(nm) to 1552.60(nm) for the corresponding strain values from 0.348 ($\mu\epsilon$) to 1.5 ($\mu\epsilon$). From the graph it can be inferred that the wavelength shift varies proportionally to that of the strain.

REFERENCES

Abdelfateh Kerrouche, J. Leighton, W. J. O. Boyle, Y. M. Gebremichael, TongSun, K.T.V. Grattan, and B. Talijsten, "Strain Measurement on a Rail Bridge Loaded to Failure Using a Fiber Bragg Grating-Based Distributed Sensor System," IEEE Sensors Journal, VOL. 8, NO. 12, DECEMBER 2008.

Fan Yang, Dawei He, Tao Wang, Yongsheng Wang, "The Real-Time Safety Monitoring of Railway Condition by FBG Sensor," IEEE Sensors Journal Vol. 15, No.6; pp. 3390 – 3394 June 2015.

- G. Pereira, L. Mikkelsen and M. McGugan,” Crack Growth Monitoring by Embedded Optical Fiber Bragg Grating Sensors Fiber Reinforced Plastic Crack Growing Detection,” IEEE Transactions on Dielectrics and Electrical Insulation Vol. 21, No.1; February 2014.
- Li Zhiquan, Wu Zhaoxia and Yan Dongmei,” Bridge Structure Monitoring System Based on Practical FBG” IEEE Sensors Journal, VOL. 14, NO. 8, AUGUST 2014.
- M. Iodice, V. Striano, G. Cappuccino, A. Palumbo and G. Cocorullo,” Fiber Bragg grating sensors based system for strain measurements, “optical Fiber Technology, Vol. 9, No. 2, pp. 57-79, 2003.